

centroLock[®]

Guided Transverse Osteotomy System

Sales Brochure

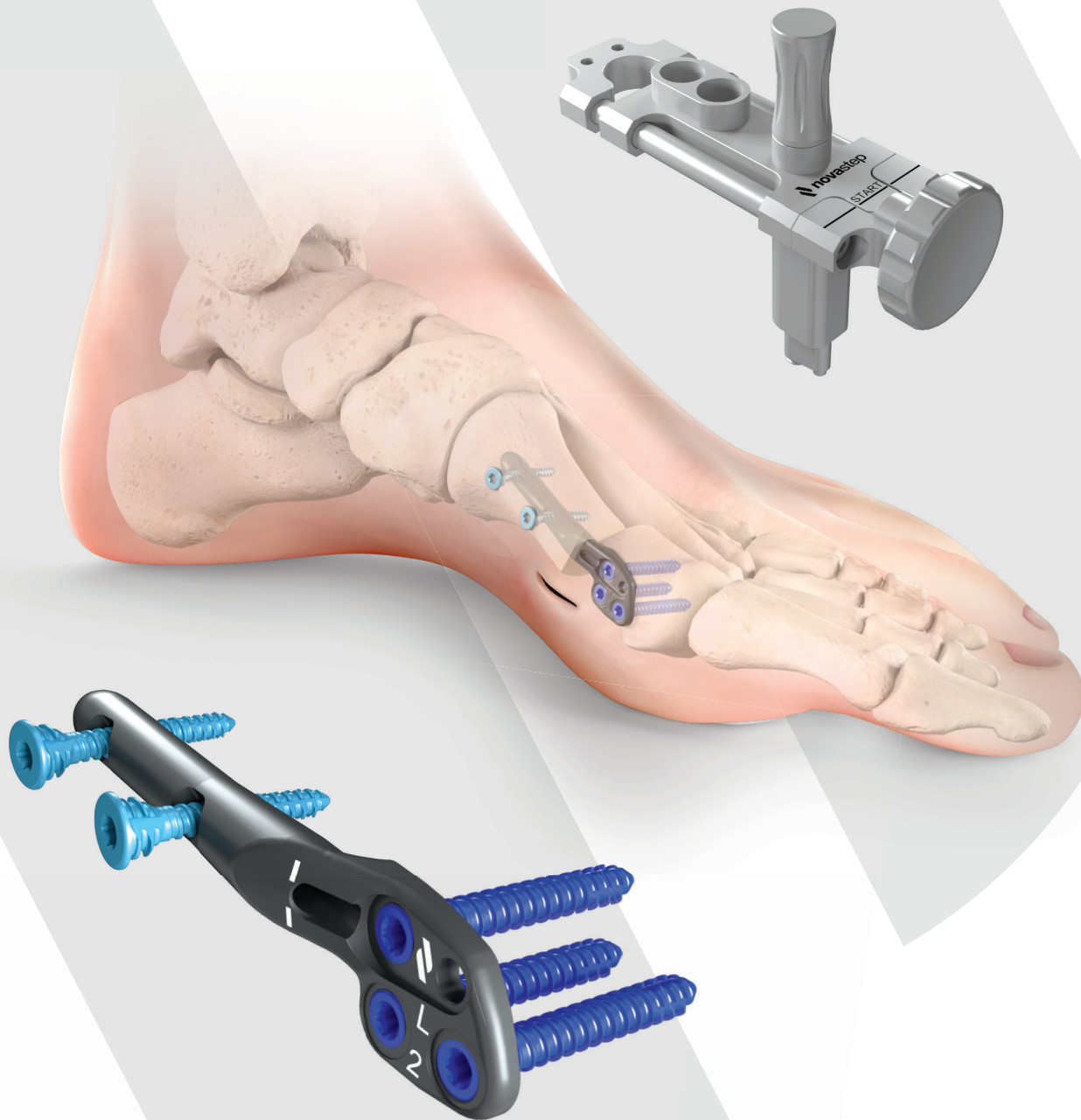

Power of a Lapidus without the fusion

Features

Centrolock was designed to evolve the standard fixation and treatment methods to correct hallux valgus. The innovative hybrid design combines a cannulated intramedullary stem with plate fixation on the metatarsal head. Powerful three plane corrections once achieved only by Lapidus procedures, can now be performed distally through a less invasive guided approach.

The combination of guided instrumentation and the CentroLock implant ensure reproducible clinical outcomes, refining hallux valgus treatment without fusing a joint. The hybrid construct provides secure fixation allowing surgeons to immediately weight bear patients following the surgical procedure.

Hybrid intramedullary implant

Combines intramedullary stem with plate fixation on the metatarsal head. The cannulated implant allows for easy manipulation of the frontal plane, increase in step off allows up to 100% translation, correcting severe Hallux Valgus deformities.

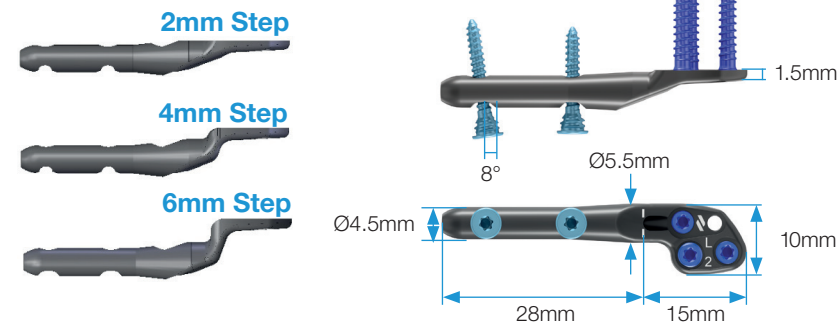

Guided Transverse Osteotomy

The transverse osteotomy provides powerful corrections in hallux valgus surgery. Utilizing this technique allows for easy manipulation in the frontal plane, while addressing severe intermetatarsal angles up to 100% translation.

Surgeons may also choose to manipulate the dorsal, plantar, length and rotational alignments of the first ray.

Centrolock implant evolves the fixation for the transverse osteotomy, providing rigid fixation eliminating the surgical correction of hallux valgus by fusion.

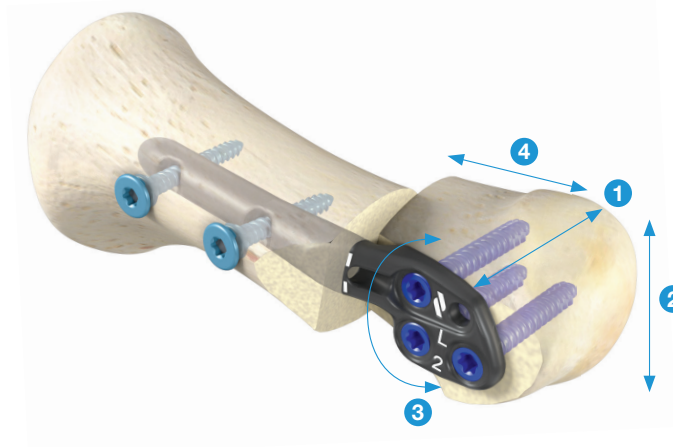

Distal Bunion Correction

The hybrid intramedullary design allows correction of hallux valgus in all three planes.

1. Lateral Translation:

2, 4, 6mm Steps increase translation of the metatarsal head.

2. Plantar / Dorsal Alignment:

Ability to manipulate the plantar or dorsal alignments of the first ray.

3. Frontal Plane:

Cannulated stem provides easy manipulation of the frontal plane, by rotating around the K-Wire.

4. Length Correction:

Surgeons may choose to lengthen, shorten or keep the first ray neutral.

Guided Instrumentation Reproducible Outcomes

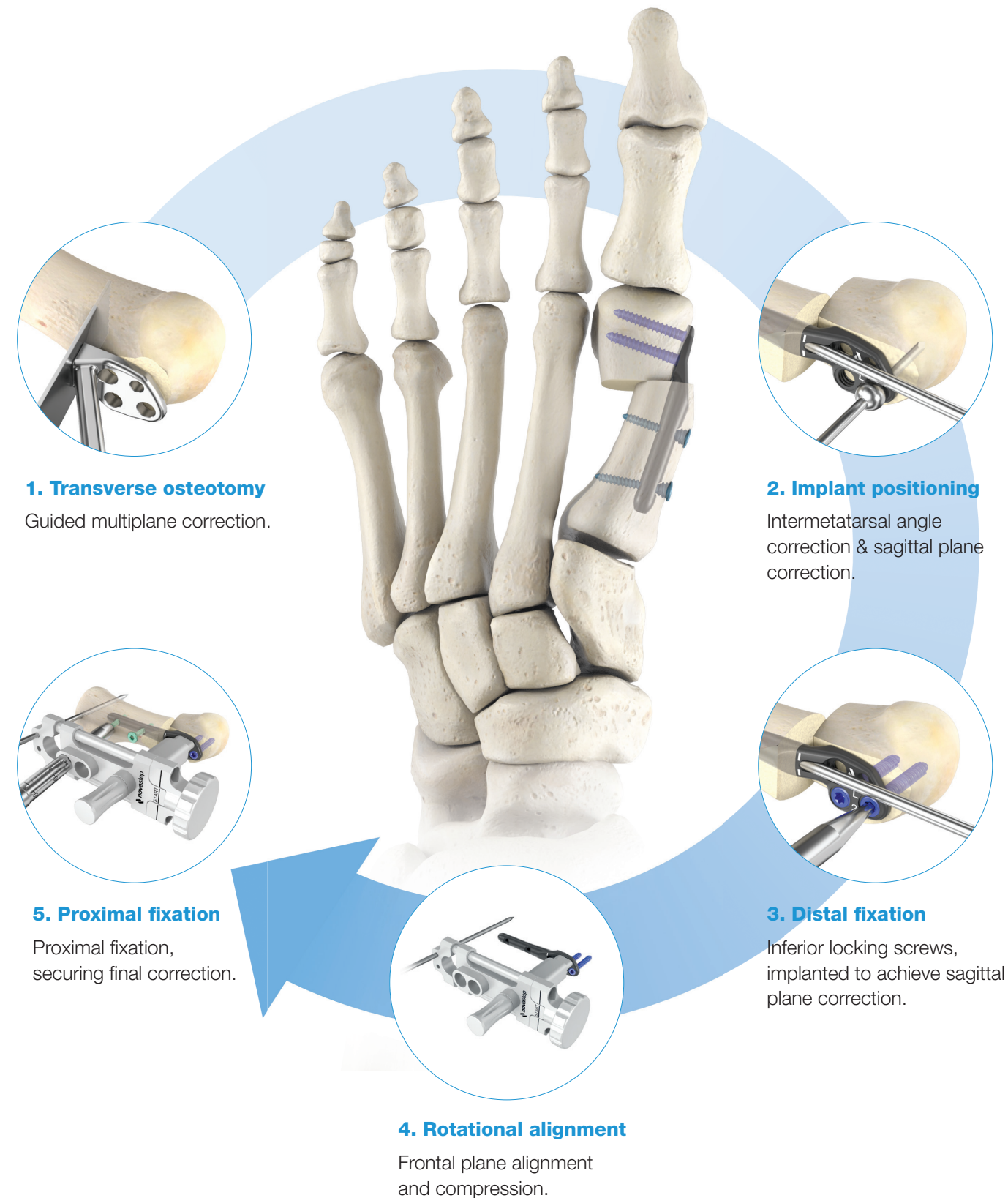

Pre-Op



Post-Op



Distributed by:

Novastep Inc.
930 Sylvan Ave, Suite 125
Englewood Cliffs, NJ 07632
(877) 287-0795
cs@novastep-us.com

CAUTION: Federal (USA) law restricts this device to sale by or on the order of a surgeon.
Rx only

Novastep Inc., or its affiliates, own, use or have applied for the following trademarks or service marks: centroLock, Novastep. All other trademarks are trademarks of their respective owners or holders.

www.novastep.life

© 2022 Novastep

Literature No: CLOCK-V3 DOR: 0222